

# PRELIMINARY PLAN

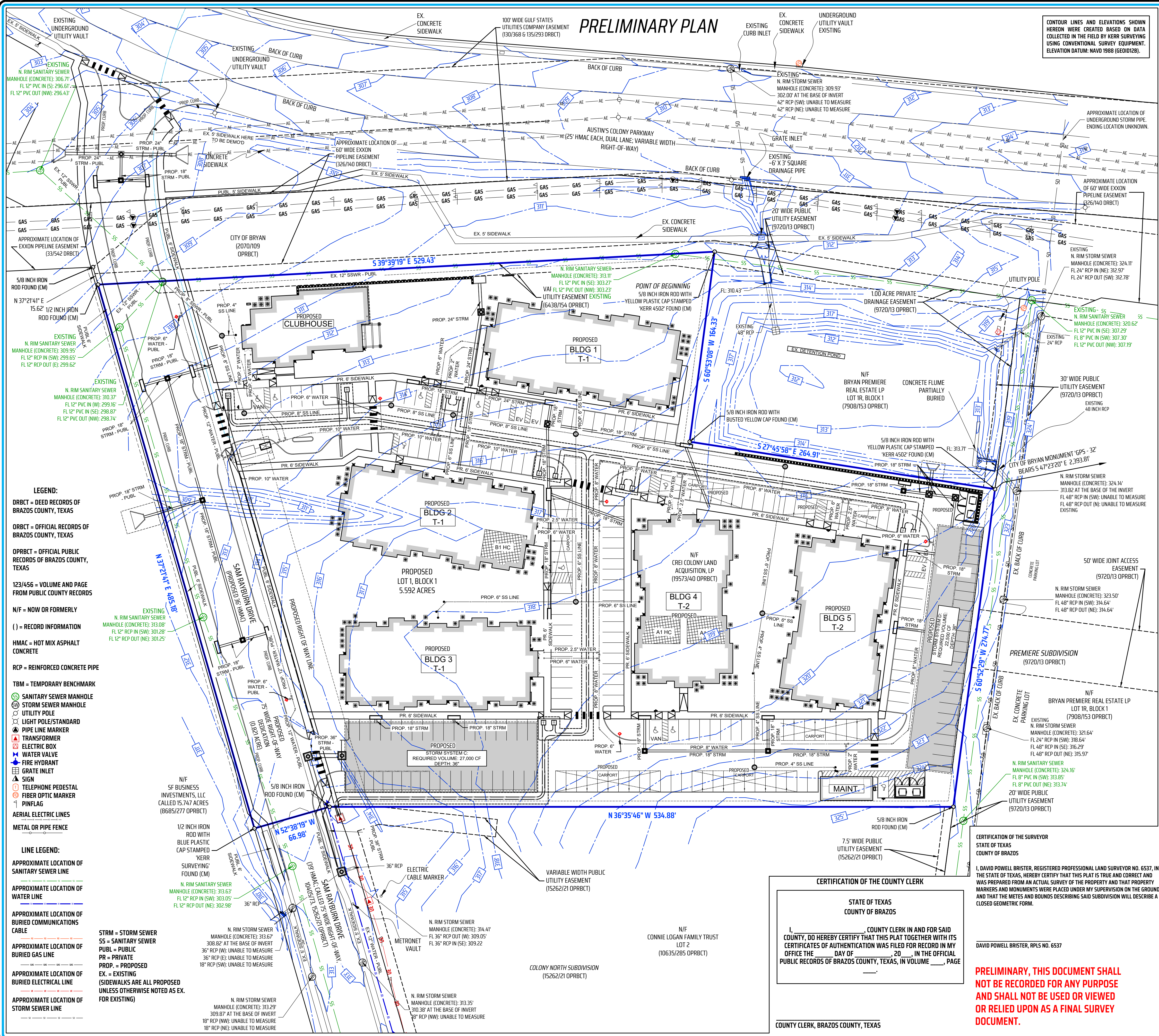

CONTOUR LINES AND ELEVATIONS SHOWN HEREON WERE CREATED BASED ON DATA COLLECTED IN THE FIELD BY KERR SURVEYING USING CONVENTIONAL SURVEY EQUIPMENT. ELEVATION DATUM: NAVD 1988 (GEOID12B).

CERTIFICATE OF OWNERSHIP AND DEDICATION  
STATE OF TEXAS  
COUNTY OF \_\_\_\_\_

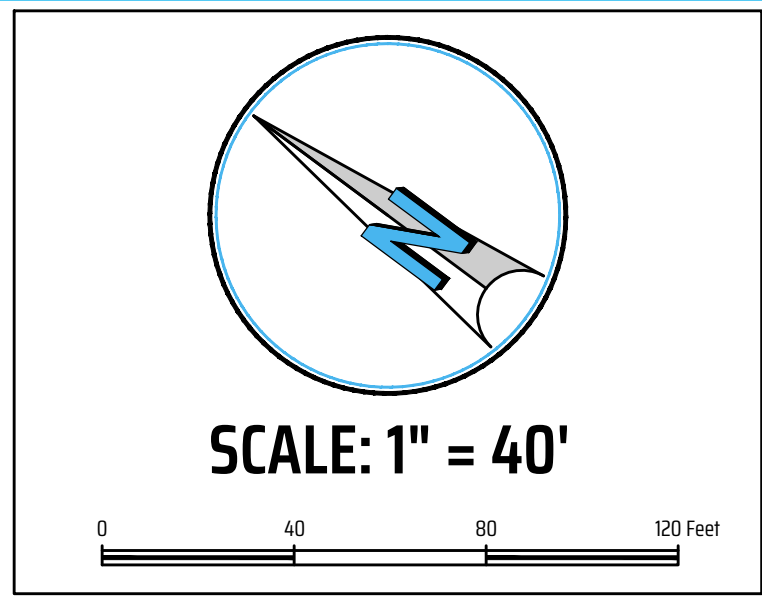

OF CREI COLONY LAND ACQUISITION, LP, THE OWNERS AND DEVELOPERS OF THE LAND SHOWN ON THIS PLAN, BEING ALL OF A CALLED 6.413 ACRE TRACT AS CONVEYED TO US IN THE OFFICIAL PUBLIC RECORDS OF BRAZOS COUNTY IN VOLUME 19573, PAGE 40, AND WHOSE NAME IS SUBSCRIBED HERETO, HEREBY DEDICATE TO THE USE OF THE PUBLIC FOREVER ALL STREETS, ALLEYS, PARKS, WATER COURSES, DRAINS, EASEMENTS, AND PUBLIC PLACES SHOWN FOR THE PURPOSES IDENTIFIED.

STATE OF TEXAS  
COUNTY OF \_\_\_\_\_

BEFORE ME, THE UNDERSIGNED AUTHORITY, ON THIS DAY PERSONALLY APPEARED KNOWN TO ME TO BE THE PERSON(S) WHOSE NAME(S) IS/ARE SUBSCRIBED TO THE FOREGOING INSTRUMENT, AND ACKNOWLEDGED TO ME THAT HE EXECUTED THE SAME FOR THE PURPOSE STATED.

GIVEN UNDER MY HAND AND SEAL OF OFFICE THIS \_\_\_\_\_ DAY OF \_\_\_\_\_, 20\_\_\_\_

NOTARY PUBLIC, \_\_\_\_\_ COUNTY, TEXAS

APPROVAL OF THE PLANNING AND ZONING COMMISSION  
I, \_\_\_\_\_, CHAIR OF THE PLANNING AND ZONING COMMISSION OF THE CITY OF BRYAN, TEXAS, HEREBY CERTIFY THAT THE ATTACHED PLAN WAS DULY FILED FOR APPROVAL WITH THE PLANNING AND ZONING COMMISSION OF THE CITY OF BRYAN ON THE DAY OF \_\_\_\_\_, 20\_\_\_\_ AND SAME WAS DULY APPROVED ON THE \_\_\_\_\_ DAY OF \_\_\_\_\_, 20\_\_\_\_ BY SAID COMMISSION.

FIELD NOTES DESCRIPTION OF A 6.413 ACRE TRACT JOHN AUSTIN LEAGUE SURVEY, ABSTRACT 2 BRYAN, BRAZOS COUNTY, TEXAS

A FIELD NOTES DESCRIPTION OF 6.413 ACRES IN THE JOHN AUSTIN LEAGUE SURVEY, ABSTRACT 2, IN BRAZOS COUNTY, TEXAS, BEING ALL OF A CALLED 6.413 ACRE TRACT OF LAND DESCRIBED IN A DEED TO CREI COLONY LAND ACQUISITION, LP IN VOLUME 19573, PAGE 40 (OPRBC), BEING ALL OF A PREVIOUSLY DESCRIBED 6.358 ACRE TRACT OF LAND DESCRIBED IN A DEED TO CARABBA INTERESTS RECORDED IN VOLUME 1085, PAGE 15 OF THE OFFICIAL PUBLIC RECORDS OF BRAZOS COUNTY, TEXAS (OPRBC); SAID 6.413 ACRES BEING MORE PARTICULARLY DESCRIBED BY METES AND BOUNDS AS FOLLOWS:

BEGINNING, at a 5/8 inch iron rod with yellow plastic cap stamped 'KERR 4502' found for an eastern corner of said Carabba tract, being the north corner of Lot 1R of the Premiere Subdivision, filed in Volume 9720, Page 13 (OPRBC), same being the north corner of a called 1.00 acre private drainage easement;

THENCE, with the common line of said Carabba tract and said Lot 1R with the 1.00 acre private drainage easement for the following two (2) courses and distances:  
1) S 60° 53' 08" W, a distance of 164.33 feet to a 5/8 inch iron rod with busted yellow cap found for an interior corner in said Carabba tract, being the west corner of said 1.00 acre private drainage easement;  
2) S 27° 45' 58" E, a distance of 264.91 feet to a 5/8 inch iron rod with yellow plastic cap stamped 'KERR 4502' found for an eastern corner of said Carabba tract, being an interior corner of said Lot 1R, same also being the south corner of said 1.00 acre private drainage easement, from which City of Bryan Monument 'GPS-32' bears S 47° 23' 20" E, a distance of 2,393.81 feet;

THENCE, continuing with the common line of said Carabba tract and said Lot 1R, S 60° 52' 29" W, a distance of 274.77 feet to a 5/8 inch iron rod found in the northwest line of said Lot 1R, being the south corner of said Carabba tract, same also being the east corner of Lot 2 of The Colony North Subdivision, filed in Volume 15262, Page 2 (OPRBC);

THENCE, with the common line of said Carabba tract and said Lot 2, N 36° 35' 46" W, a distance of 534.88 feet to a 5/8 inch iron rod found for an angle point in the southwest line of said Carabba tract, being the north corner of said Lot 2, same also being the east corner of Sam Rayburn Drive (called '70' wide right-of-way, 10495/73 OPRBC);

THENCE, with the southwest line of said Carabba tract, same being the northeast line of said Sam Rayburn Drive, N 52° 38' 19" W, a distance of 66.98 feet to a 1/2 inch iron rod with blue plastic cap stamped 'KERR SURVEYING' set in the southeast line of a called 15.747 acre tract described in a deed to SF Business Investments, LLC., in Volume 8685, Page 277 (OPRBC), being the west corner of said Carabba tract, same being the north corner of said Sam Rayburn Drive;

THENCE, with the common line of said Carabba tract and said SF Tract, N 37° 21' 41" E, a distance of 485.18 feet to a 1/2 inch iron rod found in the southeast line of said SF tract, same being the north corner of said Carabba tract;

THENCE, with the northeast line of said Carabba tract, S 39° 39' 19" E, a distance of 529.43 feet to the POINT OF BEGINNING and containing 6.413 acres of land, more or less.

APPROVAL OF THE CITY ENGINEER  
I, \_\_\_\_\_, THE UNDERSIGNED, CITY ENGINEER OF THE CITY OF BRYAN, HEREBY CERTIFY THAT THIS PLAN IS IN COMPLIANCE WITH THE APPROPRIATE CODES AND ORDINANCES OF THE CITY OF BRYAN AND WAS APPROVED ON THE \_\_\_\_\_ DAY OF \_\_\_\_\_, 20\_\_\_\_.

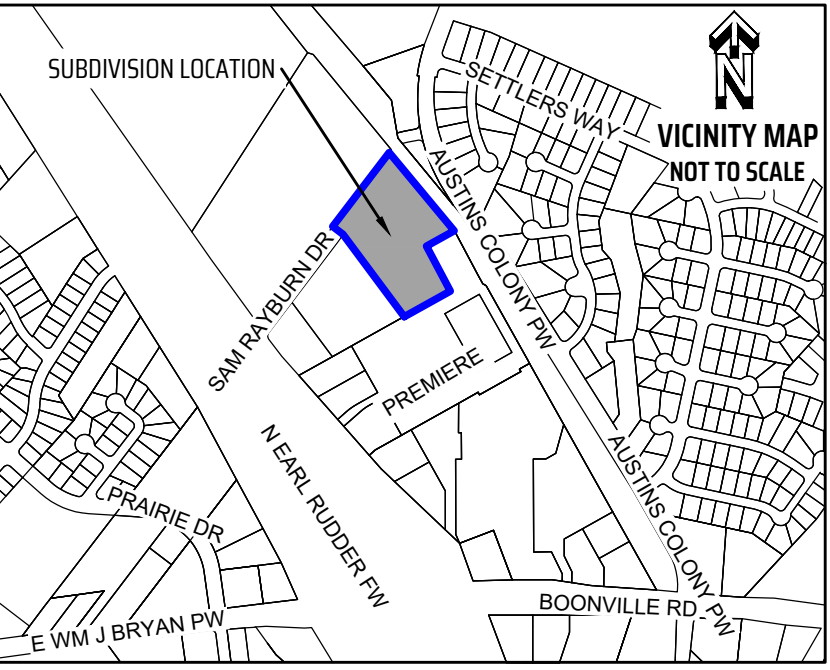

CITY ENGINEER, BRYAN, TEXAS

APPROVAL OF THE CITY PLANNER  
I, \_\_\_\_\_, THE UNDERSIGNED, CITY PLANNER AND/OR DESIGNATED SECRETARY OF THE PLANNING & ZONING COMMISSION OF THE CITY OF BRYAN, HEREBY CERTIFY THAT THIS PLAN IS IN COMPLIANCE WITH THE APPROPRIATE CODES AND ORDINANCES OF THE CITY OF BRYAN AND WAS APPROVED ON THE \_\_\_\_\_ DAY OF \_\_\_\_\_, 20\_\_\_\_.

CITY PLANNER, BRYAN, TEXAS

CERTIFICATION OF THE COUNTY CLERK  
STATE OF TEXAS  
COUNTY OF BRAZOS  
I, \_\_\_\_\_, COUNTY CLERK IN AND FOR SAID COUNTY, DO HEREBY CERTIFY THAT THIS PLAN TOGETHER WITH ITS CERTIFICATES OF AUTHENTICATION WAS FILED FOR RECORD IN MY OFFICE THE \_\_\_\_\_ DAY OF \_\_\_\_\_, 20\_\_\_\_, IN THE OFFICIAL PUBLIC RECORDS OF BRAZOS COUNTY, TEXAS, IN VOLUME \_\_\_\_\_, PAGE \_\_\_\_\_  
COUNTY CLERK, BRAZOS COUNTY, TEXAS

CERTIFICATION OF THE SURVEYOR  
STATE OF TEXAS  
COUNTY OF BRAZOS  
I, DAVID POWELL BRISTER, REGISTERED PROFESSIONAL LAND SURVEYOR NO. 6537, IN THE STATE OF TEXAS, HEREBY CERTIFY THAT THIS PLAN IS TRUE AND CORRECT AND WAS PREPARED FROM AN ACTUAL SURVEY OF THE PROPERTY AND THAT PROPERTY MARKERS AND MONUMENTS WERE PLACED UNDER MY SUPERVISION ON THE GROUND, AND THAT THE METES AND BOUNDS DESCRIBING SAID SUBDIVISION WILL DESCRIBE A CLOSED GEOMETRIC FORM.

DAVID POWELL BRISTER, RPLS NO. 6537

PRELIMINARY, THIS DOCUMENT SHALL NOT BE RECORDED FOR ANY PURPOSE AND SHALL NOT BE USED OR VIEWED OR RELIED UPON AS A FINAL SURVEY DOCUMENT.

ENGINEER  
**Kimley»Horn**  
614 HOLLEMAN DRIVE  
SUITE 1100  
COLLEGE STATION, TEXAS 77840  
TEL: (979) 775-9595  
STATE OF TEXAS  
REGISTRATION NO. F-928

FINAL PLAT  
**COLONY RIDGE SUBDIVISION**  
LOT 1, BLOCK 1 (5.592 ACRES) AND RIGHT OF WAY  
6.413 ACRES TOTAL  
VOLUME 19573, PAGE 40, OPRBC  
JOHN AUSTIN LEAGUE SURVEY, ABSTRACT 2  
BRYAN, BRAZOS COUNTY, TEXAS  
Owner: CREI COLONY LAND ACQUISITION, LP (WAYNE COURREGES III)  
1716 BRIARCREST DRIVE, 3rd FLOOR, BRYAN, TX 77802  
(512) 710-2500 | wayne@creipartners.com

SCALE: 1 INCH = 40 FEET  
SURVEY DATE: 01-16-2025 | PLAT DATE: 03-12-2025  
JOB NUMBER: 24-1498 | CAD NAME: 24-1498-S PP-PP  
POINT FILE: AUSTINI-GRID (cont); 24-1498 (job)  
DRAWN BY: TIF CHECKED BY: DPB  
PREPARED BY: KERR SURVEYING, LLC  
TPELS FIRM#10018500  
1718 BRIARCREST DRIVE, BRYAN, TEXAS 77802  
PHONE: (979) 268-3195  
SURVEYS@KERRSURVEYING.NET | KERRLANDSURVEYING.COM

# FINAL PLAT

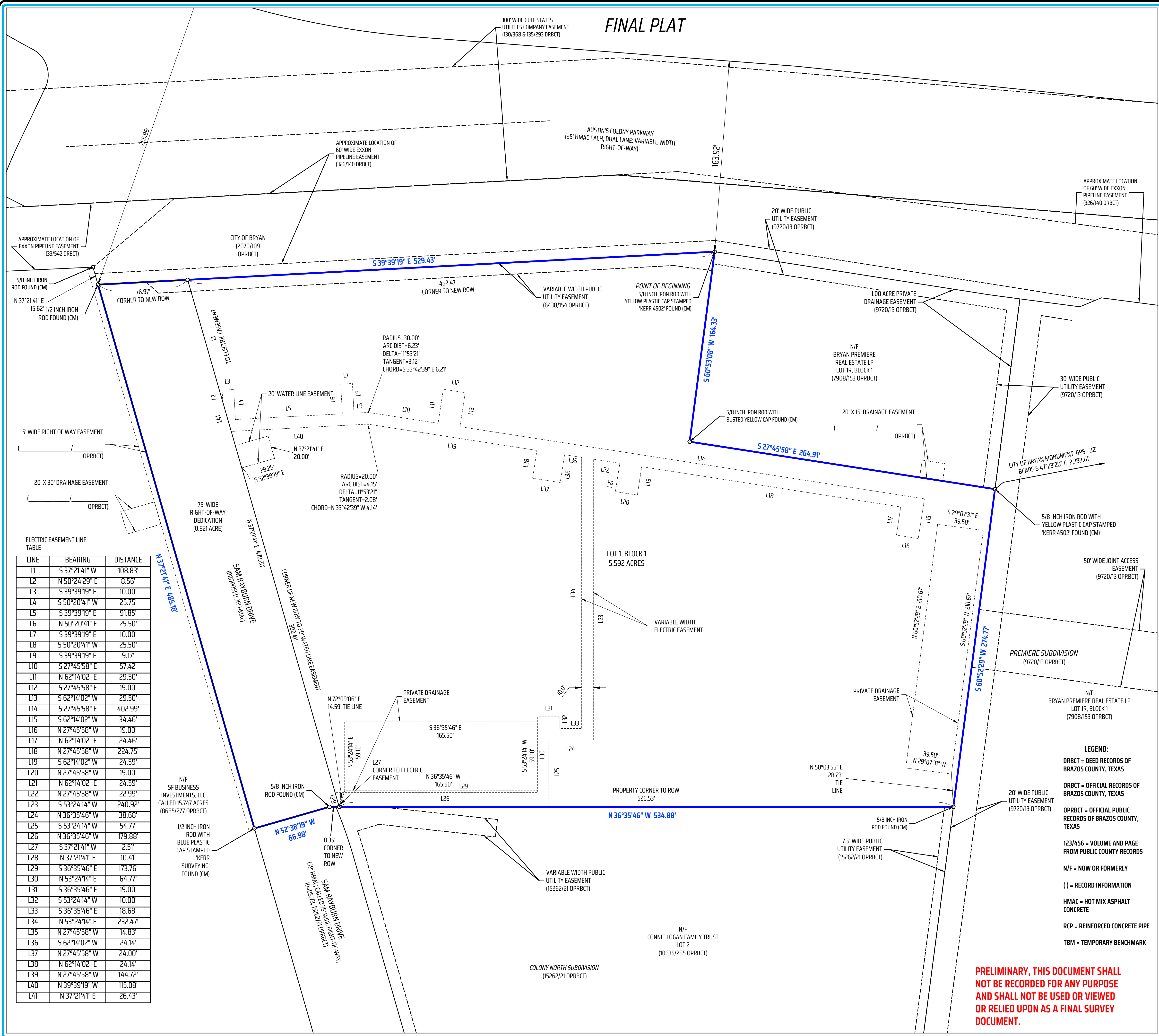
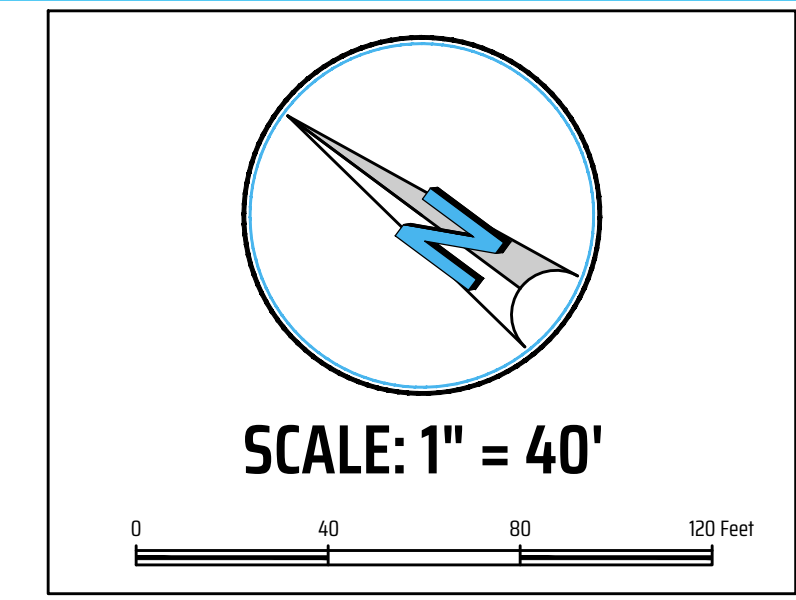

ELECTRIC EASEMENT LINE TABLE

LINE	BEARING	DISTANCE
L1	S 37°21'41" W	108.83'
L2	N 50°24'29" E	8.56'
L3	S 39°39'19" E	10.00'
L4	S 50°20'41" W	25.75'
L5	S 39°39'19" E	91.85'
L6	N 50°20'41" E	25.50'
L7	S 39°39'19" E	10.00'
L8	S 50°20'41" W	25.50'
L9	S 39°39'19" E	9.17'
L10	S 27°45'58" E	57.42'
L11	N 62°14'02" E	29.50'
L12	S 27°45'58" E	19.00'
L13	S 62°14'02" W	29.50'
L14	S 27°45'58" E	402.99'
L15	S 62°14'02" W	34.46'
L16	N 27°45'58" W	19.00'
L17	N 62°14'02" E	24.46'
L18	N 27°45'58" W	224.75'
L19	S 62°14'02" W	24.59'
L20	N 27°45'58" W	19.00'
L21	N 62°14'02" E	24.59'
L22	N 27°45'58" W	22.99'
L23	S 53°24'14" W	240.92'
L24	N 36°35'46" W	38.68'
L25	S 53°24'14" W	54.77'
L26	N 36°35'46" W	179.88'
L27	S 37°21'41" W	2.51'
L28	N 37°21'41" E	10.41'
L29	S 36°35'46" E	173.76'
L30	N 53°24'14" E	64.77'
L31	S 36°35'46" E	19.00'
L32	S 53°24'14" W	10.00'
L33	S 36°35'46" E	18.68'
L34	N 53°24'14" E	232.47'
L35	N 27°45'58" W	14.83'
L36	S 62°14'02" W	24.14'
L37	N 27°45'58" W	24.00'
L38	N 62°14'02" E	24.14'
L39	N 27°45'58" W	144.72'
L40	N 39°39'19" W	115.08'
L41	N 37°21'41" E	26.43'

**GENERAL NOTES**

BEARING SYSTEM SHOWN HEREON IS BASED ON TEXAS COORDINATE SYSTEM OF 1993, CENTRAL ZONE (4203), GRID NORTH AS ESTABLISHED FROM GPS OBSERVATION USING THE LEICA SMARTNET NAD83 (NA2011) EPOCH 2010 MULTI-YEAR CORS SOLUTION 2 (MYCS2).

DISTANCES SHOWN HEREON ARE SURFACE DISTANCES UNLESS OTHERWISE NOTED. TO OBTAIN GRID DISTANCES (NOT AREAS) DIVIDE BY A COMBINED SCALE FACTOR OF 1.0001316573897 (CALCULATED USING GEOD12B).

(CM) INDICATES CONTROLLING MONUMENT FOUND AND USED TO ESTABLISH PROPERTY BOUNDARIES.

UNDERGROUND UTILITIES ARE APPROXIMATED BASED ON ABOVE GROUND FEATURES, AVAILABLE MAPS AND MARKINGS BY UTILITY PROVIDERS. ADDITIONAL UTILITIES MAY EXIST THAT ARE NOT SHOWN ON THIS SURVEY.

THIS TRACT DOES NOT LIE IN A FLOODPLAIN. THIS TRACT LIES WITHIN FLOOD ZONE 'X' UNSHADED AND DOES NOT LIE WITHIN A SPECIAL FLOOD HAZARD AREA SUBJECT TO THE 1% ANNUAL CHANCE FLOOD (100 YEAR FLOOD PLAIN) ACCORDING TO THE BRAZOS COUNTY FLOOD INSURANCE RATE MAP (FIRM) PANEL NO. 48041C0215F, REVISED DATE: 04-02-2014.

THIS TRACT IS ZONED PD-H PLANNED DEVELOPMENT-HOUSING ENACTED THROUGH ORD. #2708, ADOPTED SEPTEMBER 10, 2024.

ALL MINIMUM BUILDING SETBACKS SHALL BE IN ACCORDANCE WITH THE CITY OF BRYAN CODE OF ORDINANCES.

CONTOUR LINES AND ELEVATIONS SHOWN HEREON WERE CREATED BASED ON DATA COLLECTED IN THE FIELD BY KERR SURVEYING USING CONVENTIONAL SURVEY EQUIPMENT. ELEVATION DATUM: NAVD 1988 (GEOD12B).

WHERE ELECTRIC FACILITIES ARE INSTALLED, BTU HAS THE RIGHT TO INSTALL, OPERATE, RELOCATE, CONSTRUCT, RECONSTRUCT, ADD TO, MAINTAIN, INSPECT, PATROL, ENLARGE, REPAIR, REMOVE AND REPLACE SAID FACILITIES UPON, OVER, UNDER AND ACROSS THE PROPERTY INCLUDED IN THE PUE, AND THE RIGHT OF INGRESS AND EGRESS ON PROPERTIES ADJACENT TO THE PUE TO ACCESS ELECTRIC FACILITIES.

BEARINGS, DISTANCES, AND CURVE DATA SHOWN INSIDE TRACT FOR PROPERTY CORNERS, LINES, AND/OR EASEMENTS.

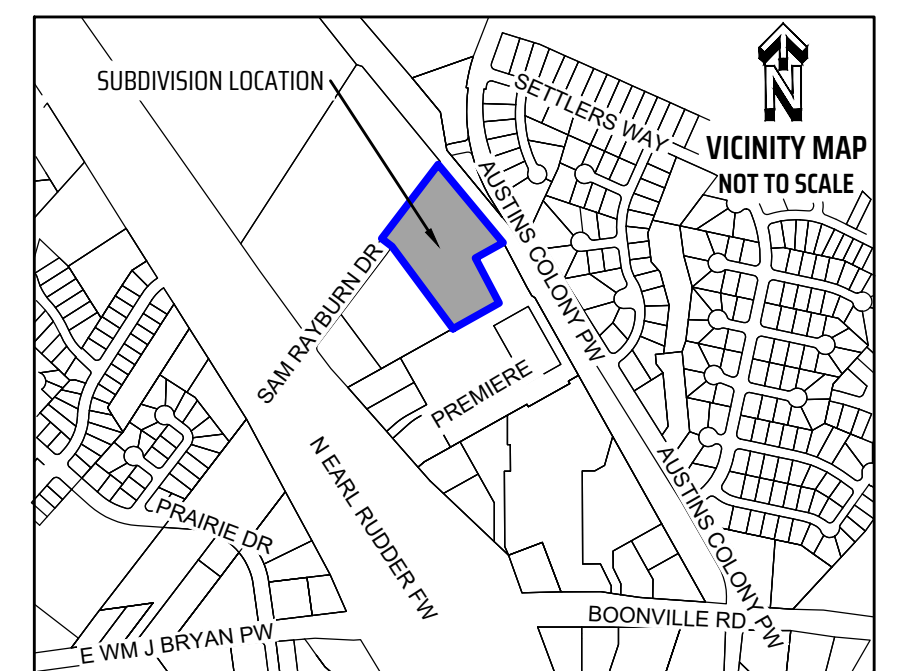

- LEGEND:**
- ORBCT = DEED RECORDS OF BRAZOS COUNTY, TEXAS
  - ORBCT = OFFICIAL RECORDS OF BRAZOS COUNTY, TEXAS
  - OPRBCT = OFFICIAL PUBLIC RECORDS OF BRAZOS COUNTY, TEXAS
  - 123/456 = VOLUME AND PAGE FROM PUBLIC COUNTY RECORDS
  - N/F = NOW OR FORMERLY
  - ( ) = RECORD INFORMATION
  - HMAC = HOT MIX ASPHALT CONCRETE
  - RCP = REINFORCED CONCRETE PIPE
  - TBM = TEMPORARY BENCHMARK

**PRELIMINARY, THIS DOCUMENT SHALL NOT BE RECORDED FOR ANY PURPOSE AND SHALL NOT BE USED OR VIEWED OR RELIED UPON AS A FINAL SURVEY DOCUMENT.**

**ENGINEER**  
**Kimley»Horn**  
 614 HOLLEMAN DRIVE E  
 SUITE 1100  
 COLLEGE STATION, TEXAS 77840  
 TEL: (979) 775-9595  
 STATE OF TEXAS  
 REGISTRATION NO. F-928

**FINAL PLAT**  
**COLONY RIDGE SUBDIVISION**

LOT 1, BLOCK 1 (5.592 ACRES) AND RIGHT OF WAY  
 6.413 ACRES TOTAL

VOLUME 19573, PAGE 40, OPRBCT  
 JOHN AUSTIN LEAGUE SURVEY, ABSTRACT 2  
 BRYAN, BRAZOS COUNTY, TEXAS

Owner: CREI COLONY LAND ACQUISITION, LP (WAYNE COURREGES III)  
 1716 BRIARCREST DRIVE, 3rd FLOOR, BRYAN, TX 77802  
 (512) 710-2500 | wayne@creipartners.com

SCALE: 1 INCH = 40 FEET

**KERR SURVEYING**  
 "When one person stands to gain over another, the facts must be uncovered"  
 JOB NUMBER: 24-1498 | CAD NAME: 24-1498-S PP-PP  
 POINT FILE: AUSTINI-GRID (cont); 24-1498 (job)  
 DRAWN BY: TIF CHECKED BY: DPB  
 PREPARED BY: KERR SURVEYING, LLC  
 TBPELS FIRM#10018500  
 1718 BRIARCREST DRIVE, BRYAN, TEXAS 77802  
 PHONE: (979) 268-3195  
 SURVEYS@KERRSURVEYING.NET | KERRLANDSURVEYING.COM